

# Benefits of Rilsan® PA11-based coatings for piping systems

## Solutions for the Fluid Transfer Industry

Rilsan® Polyamide 11-based coatings have been used in water treatment plants and fluid transportation systems since 1967. These polyamide 11 coatings offer unique benefits by protecting metal parts from corrosion, mechanical impact and chemical attack, while preserving water quality.

### PRESERVING DRINKING WATER QUALITY

Specially designed Rilsan® PA11-based coatings meet the requirements of various potable water contact regulations. Several grades have been granted official approvals\* in many countries:

- France: ACS certification (circular DGS/VS4/N°99.217)
- United Kingdom: WRAS certification
- Germany: KTW and W270 certifications
- Netherlands: KIWA-ATA certification
- United States: NSF61 listing
- Japan: JWVA certification (Ministry of Health)
- Australia: AS4020 certification

\* Please consult your Arkema representative to know more about



### REDUCING YOUR CAPITAL EXPENDITURE

#### OFFERING COST COMPETITIVE PIPING SOLUTIONS

The Rilsan® PA11-based coating system provides similar or superior corrosion resistance than most stainless steel grades, including duplex and super duplex, at a much lower cost.

The graphic on the right compares the cost of a Rilsan® PA11 coated piping system with different stainless steel solutions. This includes the redesign cost due to the use of flanges.

### COST COMPARISON

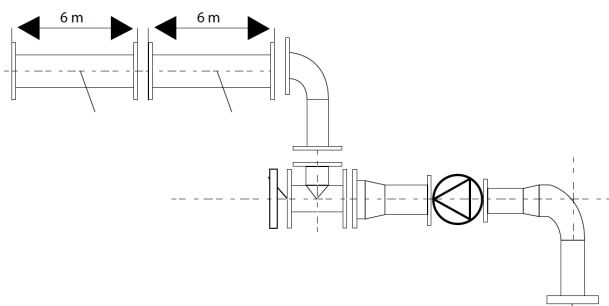
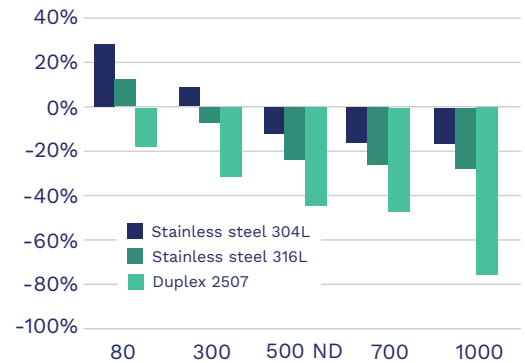

Carbon steel + Rilsan® coating design

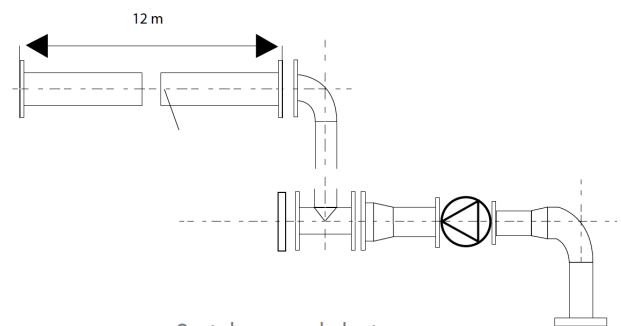

Stainless steel design

## PROTECTING PARTS DURING HANDLING AND STORAGE

Rilsan® PA11-based coatings possess remarkable physical and mechanical properties compared to standard coating solutions:

- Excellent weathering resistance
- Very low moisture pick-up
- Outstanding impact resistance
- High flexibility

These properties greatly minimize the risk of damage and thus installation cost and delays.



## MINIMIZING OPERATIONAL EXPENDITURE EXTENDING THE LIFETIME OF YOUR INSTALLATION

Rilsan® PA11-based coatings provide excellent protection for both new and refurbished parts of all shapes (pipes, flanges, cross fittings, elbow joints, 4-way joints, Y-joints, etc.).

The polyamide 11 coating protects steel, cast iron and aluminium from the harshest environments:

- Effluents and seawater.
- Cathodic protection.
- Water treatment chemicals (chlorines, chlorides, hypochlorites, hyposulphites, ozones...).
- Ultra filtration, microfiltration and reverse osmosis membrane cleaning agents.

With its excellent resistance to a wide range of extreme and repeated exposures, Rilsan® PA11 provides a technical solution in applications that are too demanding for most stainless steel grades.

Track records include:

- 40 years of operation in water treatment plants without maintenance.
- 10 years of immersion in seawater without any rust or disbondment.
- 25 years of utilisation in desalination plants to solve rapid corrosion occurring with most stainless steel.
- Numerous references in ultra filtration and seawater reverse osmosis membrane filtration systems to protect piping from aggressive membrane cleaning agents.
- 30 years of durability in shipbuilding application such as seawater cooling systems and ballast piping.
- 10 years of operation in pumping station to prevent rapid erosion of pipes due to water containing clays.

## SAVING ENERGY THROUGHOUT THE YEARS

Smooth surface helps reduce pressure loss while ensuring effective flow.

Surface smoothness is maintained over the years thanks to:

- Prevention of fouling and scale deposition
- Outstanding wear resistance
- Exceptional cavitation resistance



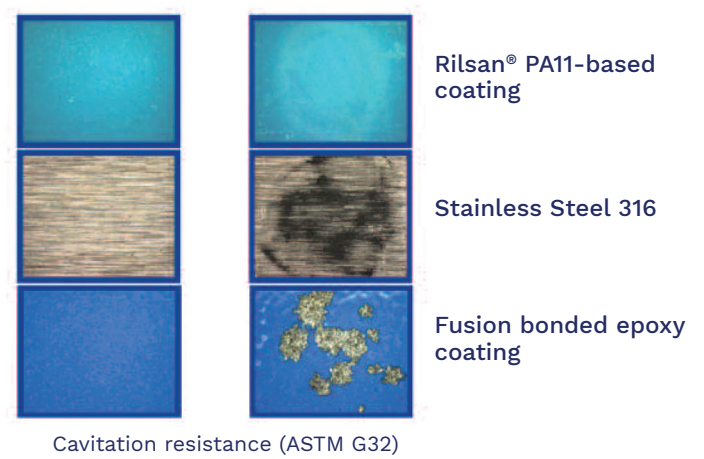
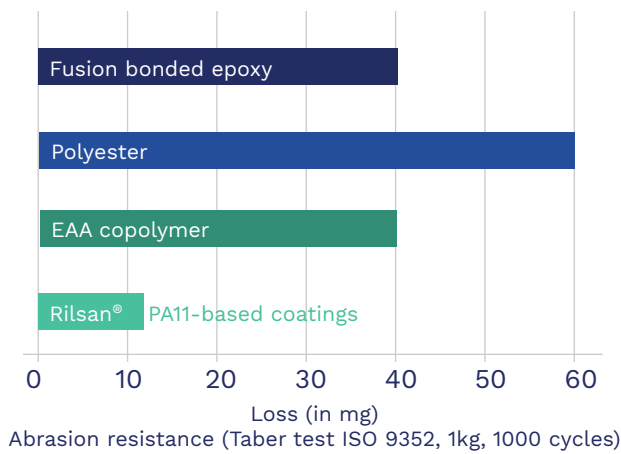

## PROPERTIES OF RILSAN® PA11-BASED COATINGS

### TYPICAL RESULTS FOR COATING APPLIED ACCORDING TO ARKEMA RECOMMENDED PROCEDURES

Properties	Standard	Unit	Value
Thickness of coating	ISO 2808	µm	Min 250 µm
Hardness	ISO 868		75-85 Shore D
Dielectric strength	ASTM D 149	kV/mm	30-36 minimum at 300-450 m
Impact resistance Sphere: Ø 16 mm	ASTM G 14	J	2 minimum
Resistance to salt spray 1000 h at 5% NaCl, 35Co Adhesion class			3 or better
Resistance to hot water 50 ± 2Co, 14 days Adhesion class	AS/NZS 4158-2003 AS3862 AS1580.408.2		1 or better
Resistance to waste water 23 ± 3Co, 30 days Adhesion class	EN10310		3 or better
Resistance to demineralized water 23 ± 3Co, 30 days Adhesion class	EN10310		3 or better
Cavitation resistance	ASTM G32	/hour	5 maximum
Abrasion resistance CS 17, 1 kg, 1000 cycles	ISO 9352	mg	20
High pressure cycle resistance 2000 cycles - salted wa- ter (35g/l)	Autoclave testing 80 bars Instantaneous decom- pression EN10310	No degrada- tion	3 or better

### CHEMICAL RESULTS FOR COATING APPLIED ACCORDING TO ARKEMA RECOMMENDED PROCEDURES at ambient temperature to 50°C

Inorganic salts (chlorides, sulphates, nitrates, phosphates, ...)	No degradation
Saturated solution, 18 month immersion	No loss of adhesion
Alkalis (ammonium, sodium and potassium hydroxides, )	No degradation
pH < 10, 18 month immersion	No loss of adhesion
Acids (hydrochloric, sulphuric acids, ... )	No degradation
pH > 3, 18 month immersion	No loss of adhesion
Chlorine	No degradation
10 ppm – 15 years	No loss of adhesion
Sodium hypochlorite	No degradation
2.6% active chlorine – 18 month immersion	No loss of adhesion
Ozone	No degradation
5 ppm - 5 year immersion	No loss of adhesion
Membrane cleaning cycles	No degradation
HCl pH 2, and 1% NaHSO3 – 500 hours	No loss of adhesion
Membrane cleaning cycles	No degradation
NaOH pH 12 5 min - HCl pH 2 5 min - 528 cycles	No loss of adhesion

These are generic indications. Rilsan® PA11-based coating can resist to harsher conditions, depending on the time of exposure and the nature of the chemicals. Please consult your Arkema representative for more information

## MINIMIZING OPERATIONAL EXPENDITURE

Like all other coatings, full effectiveness is only obtained by satisfactory metal pre-treatment and controlled application processes. Arkema has collaborated with the industry to set performance standards that help designers specify the proper Rilsan® PA11-based coating systems. These define the coating system requirements, the application procedures, as well as the quality control steps required to achieve the desired performance.

- Rilsan® PA11-based coating systems comply with different performance standards for piping systems:
- Europe — EN 10310
- USA — AWWA C-224
- Japan — JWWA WSP067
- UK — WIS 4-52-01
- Australia — AS/NZS 4158
- Holland — KIWA K-759

To support engineering companies looking to outsource the coating operation, Arkema has developed the Approved Coating Applicator (ACA) Program, a worldwide network of customer coaters who have demonstrated the capability to produce a uniform and top-of-the-line quality.

Rilsan® Fine Powders is a registered trademark of Arkema.  
© 2025 Arkema Inc. All rights reserved

**Arkema Headquarter**  
51 Espl. du Général de Gaulle  
Immeuble LIGHTWELL,  
92800 Puteaux  
France  
T +33 (0)1 49 00 80 80

Disclaimer - Please consult Arkema's disclaimer regarding the use of Arkema's products on <https://www.arkema.com/global/en/products/product-safety/disclaimer/>

Arkema France, a French *société anonyme* registered at the Trade and Companies Register of Nanterre under the number 319 632 790

[arkema.com](https://www.arkema.com)

**ARKEMA**